



SNAPPY LADDER INSTRUCTION MANUAL

A practical single - sided mobile ladder
that can be used anywhere "EN 131-7"



where.



FEATURES

- Ladder width 52cm, rung gap 28cm with guardrail height 96 cm.
- 2 Fixed castor wheels.
- Spacious platform : 41.0 cm x 62.0 cm
- Platform railing with intermediate & toe board.
- Maximum load capacity : 150kg
- Read Safety Instruction for Safer usage.
- Designed as per EN131 Standard.

SNAPPY PLATFORM LADDER BS EN 131-1,2,3&7 (TECHNICAL SPECIFICATION)										
Product Code	Max Working Height (m)	Max (Inclination Railing) Total Height (m)	Platform Height (m)	Stabilizer Bar Width (m)	Base Length (m)	No of Rungs	Platform Spacious (L*W) (m)	Weight (kg)	CBM (m3) 1 Qty	CBM (m3) 2 Qty
SL3AL	3	1.96	1	0.81	1.47	3	0.64*0.435	14	1.348	1.582
SL5AL	3.5	2.46	1.5	0.81	1.9	5	0.62*0.40	23.8	1.699	1.993
SL7AL	4	3	2.03	0.91	2.36	7	0.62*0.41	29.2	2.327	2.73
SL8AL	4.27	3.23	2.27	0.91	2.69	8	0.62*0.42	30.8	2.629	3.085
SL10AL	4.86	3.83	2.86	1.01	3.11	10	0.62*0.43	34.2	3.234	3.795

ALWAYS READ THE INSTRUCTION MANUAL FOR SAFER ASSEMBLY OF SNAPPY



- ☎ +971 4 885 5001
- ✉ sales@ascenduae.com
- 🌐 www.ascenduae.com
- 📍 Nad Al Hamar, Dubai



SNAPPY LADDER INSTRUCTION MANUAL

A practical single - sided mobile ladder
that can be used anywhere "EN 131-7"

Ladders – Proper Set Up

1. **DANGER!** Metal Conducts Electricity! Do not let ladders of any material come in contact with live electrical wires.
2. Make sure ladder is fully open, spreaders secure, and pail shelf in position.
3. Place on firm level surface with a secure footing. Do not use on slippery surfaces. Do not place on boxes, unstable bases or scaffolds to gain additional height. Do not place in front of door opening towards ladder.

Ladders – Proper Climbing & Use

1. Face ladder when climbing up or down, keep body centered between side rails.
2. Maintain a firm grip. Use both hands in climbing.
3. Never climb a ladder from the side unless ladder is secure against side wise motion, nor climb from one ladder to another.
4. Do not walk or jog ladder when standing on it.
5. Do not stand, climb or sit on ladder top, pail shelf, braces, or back section.
6. Do not overload, ladder is meant for one person.
7. Keep ladder close to work, avoid pushing or pulling off the side of ladders.
8. Clutter around the base of the ladder should be removed from the working area by setting up traffic barrier..
9. Block off the area of work.
10. Only one person at a time should climb a ladder.
11. Maintain a 3 point contact with ladder.
12. Never leave a ladder set up unattended.
13. Never allow children to climb a ladder.
14. Keep shoes clean, leather soles should not be worn.

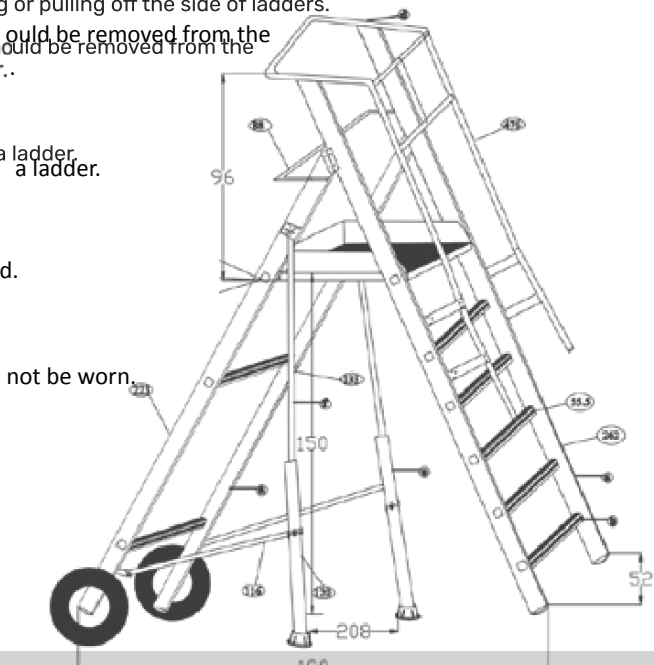



SNAPPY LADDER ASSEMBLY INSTRUCTION

A practical single - sided mobile ladder
that can be used anywhere "EN 131-7"



Step 1 Hold the snappy ladder in vertical position.



Step 2
Expand the sides of snappy ladder horizontally for free standing of ladder. Fit platform in position.



Step 3

Expand both the stabilizers horizontally for increasing stability.



Step 4

Close the guardrail gate by moving down for safe working.



SNAPPY LADDER INSTRUCTION MANUAL

A practical single - sided mobile ladder
that can be used anywhere "EN 131-7"

The following "GREEN" pictograms indicate proper use. The following "RED" pictograms indicate misuse and are provided as a visual reminder for use. They are not an exhaustive list of use instructions or warnings.

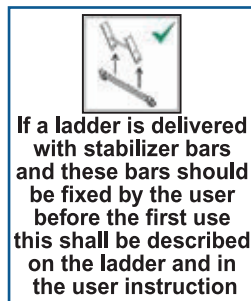
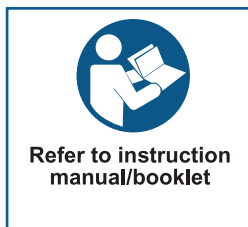
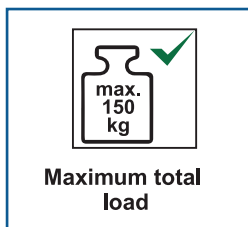
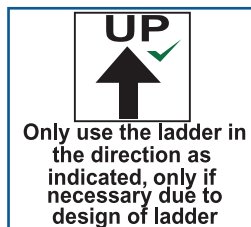
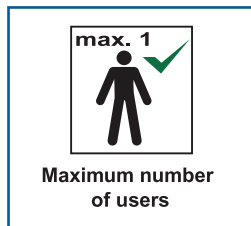



SNAPPY LADDER INSTRUCTION MANUAL

A practical single - sided mobile ladder
that can be used anywhere “EN 131-7”

The following “GREEN” pictograms indicate proper use. The following “RED” pictograms indicate misuse and are provided as a visual reminder for use. They are not an exhaustive list of use instructions or warnings.

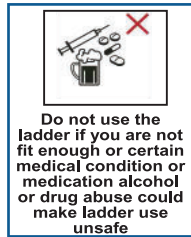
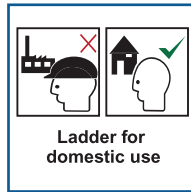



SNAPPY LADDER INSTRUCTION MANUAL

A practical single - sided mobile ladder
that can be used anywhere "EN 131-7"

IMPORTANT INSTRUCTION BEFORE USE

For professional use, a risk assessment shall be carried out
respecting the legislation in the country of use.

- Face ladder while climbing up or down, keep body centered between side rails.
- Maintain a firm grip use both hands while climbing.
- Never climb a ladder from the side unless ladder is secure against side wise motion, nor climb from one ladder to another.
- Do not over reach, move ladder when needed.
- Do not walk, jog or move ladder when standing on it.
- Do not stand, climb or sit on ladder top, pail shell, braces or back section.
- Do not overload ladder is meant for one person. Do not use as a platform or plank.
- Keep ladder close to work, avoid pushing or pulling off the side of the ladder.
- Clutter around the base of the ladder should be removed from the working area by setting up traffic barrier.
- When positioning the ladder take into account risk of collision with the ladder e.g. From pedestrian, vehicles, or doors. Secured doors (not fire exits) and windows when possible in the working area. Do not connect two ladders to each other.
- Never leave a ladder setup unattended.
- Make sure you have a ladder high enough to do the job. Position it correctly at the right angle and tie it in whenever possible.
- Be especially careful when carrying out tasks that apply unbalancing load, such as drilling.

Inspection Before Each Use

1. Make sure all rivets and joints, nuts and bolts are tight; feet steps and rungs are secure, spreaders and pail shelf function properly (on step ladders).
2. For professional use a risk assessment shall be carried out respective the legislation in the country & use.
3. If you are in poor health subject to fainting spells, have physical handicap that would impair your climbing ability, or if you are under the influence of any drug or alcohol (including legal drugs that may cause drowsiness), you should not use the ladder.
4. Stay focused on safety whenever you are on the ladder.
5. Do not move a ladder while standing on it.
6. Use non-conductive ladders for unavoidable live electrical works.
7. Inspect upon receipt and before each use. Never climb a damaged, bent or broken ladder, all working parts must be in good working order.

Proper Care & Storage of Ladders

1. Store in a safe and dry place.
2. Never store materials on ladders.
3. Regularly clean and lubricate the ladder's moving parts. Clean the rungs and steps.



SNAPPY LADDER INSTRUCTION MANUAL

A practical single - sided mobile ladder
that can be used anywhere "EN 131-7"

General Ladder Safety

If ladder is used properly and according to safety guidelines, it will give many years of trouble free service. However, if proper cautions are not taken, a ladder can be involved in an accident. Please read and follow all instructions and labels accompanying each ladder.

Two factors that deserve particular attention are proper ladder selection and electrical shock precautions

Pay close attention to the Duty Rating of the ladder and the combined weight of the user and materials.

Be aware of wires, electrical devices and live electrical circuits. Metal ladders conduct electricity and can create a danger of electrocution. Failure to read and follow instructions regarding electrical safety could result in serious personal injury or death.

General Ladder Safety Instructions

- Make sure ladder is fully open, spreaders secure, and pail shelf in position.
- Place on firm level surface with a secure footing. Do not use on slippery surfaces. Do not place on boxes, unstable bases or scaffolds to gain additional height. Do not place in front of door opening towards ladder.
- Suitable stabilizing elements should be used. Both upper ends of the ladder must be leaned against the wall so that the load is transformed uniformly.
- The ladders must never be moved from above.
- Never climb a closed step ladder it may slip out.
- Check the rungs / steps are not missing, loose, excessively worn, corroded and damaged.
- Check that the entire ladder is free from contaminants (e.g., dirt, mud paint, oil or grease).
- Check that the platform (if fitted) has no missing parts or fixings and is not damaged or corroded.
- Check that the stiles / legs (uprights) are not bent, bowed, twisted, dented, cracked, corroded or rotten.
- Check that the fixings (usually rivets, screw or bolt) are not missing, loose or corroded.
- Check that hinges between front and rear sections are not damaged, loose or corroded.
- Check that the rung hooks are not missing, damaged, loose or corroded and engage properly on the rungs.
- Check that ladder feet / end caps are not missing, loose, excessively worn, corroded or damaged.
- Check that locking catches (if fitted) are not damaged or corroded and function correctly.
- Don't modify the ladder design.
- Stop using the ladder when wind speed exceeds 20 miles / hour or in any adverse weather condition.
- Check that locking stays horizontal, back rails and corner braces are not missing, bent, loose, corroded or damaged.
- Ensure the ladder is suitable for task. Prevent damage to the ladder when transporting e.g. by fastening and ensure they are suitably by placed to prevent damage.
- Do not spend long periods on ladder without regular breaks (Tiredness is a risk).
- Do make sure you are wearing the correct footwear.
- Check that guide brackets are not missing, damaged, loose or corroded and engage properly on mating stile.
- Check that the stiles / legs around the fixing point for other components are in good condi-